

DIMENSIONS

HHP CONCEALED CEILING WITH PLENUM

Redefine your comfort zone™ | www.titus-hvac.com

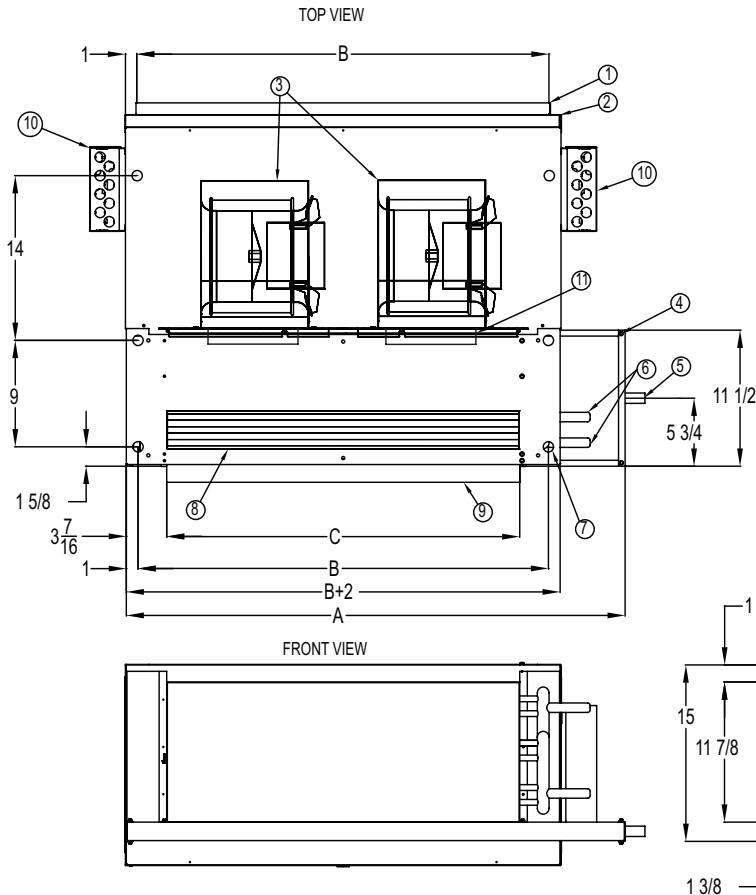

1. Return Air Flange
2. Filter Bottom Return (Optional)
3. Motor/Blower(s) Assembly
4. Condensate Tray (Double Wall optional)
5. Condensate Connection 3/4" MNPT
6. Coil Connections (2-Pipe Shown)
7. Hanging Points
8. Coil
9. Supply Air Flange
10. Electric Control Panel - Note: Control box may be mounted on either side
11. Electric Heaters (optional)

Note: Right Hand Rear Return Unit Shown

Model	Dimensions (inches)					Approx. Weight (pounds)
	A	B	C	D	Filter	
HHP06	25½	18	13	5/8	20 x 17 x 1	81
HHP08	30½	23	18	5/8	25 x 17 x 1	94
HHP10	33½	26	21	7/8	28 x 17 x 1	106
HHP12	38½	31	26	7/8	33 x 17 x 1	117
HHP14	42½	35	30	7/8	37 x 17 x 1	154
HHP16	46½	39	34	7/8	41 x 17 x 1	175
HHP18	51½	44	39	7/8	46 x 17 x 1	195
HHP20	55½	48	43	7/8	50 x 17 x 1	212

All dimensions are in inches